

## SOFT GROUND TUNNEL STABILITY: ANALYSIS AND REINFORCEMENT STRATEGIES

Joshua Thompson<sup>1</sup>, Daniel Wright<sup>2</sup>, Olivia Adams<sup>3</sup>, and Emily Taylor\*<sup>3</sup>

<sup>1</sup> Department of Physics, University of Oxford, UK

<sup>2</sup> Department of Civil Engineering, University of Manchester, UK

<sup>3</sup> Department of Computer Science, University of Sydney, Australia

### ABSTRACT

The tunnels are artificial underground passages generally used for transporting men and materials. One of the most important discussions in the field of tunneling is settlement and stability. In recent, numerical analysis has been found effective in identifying the performance of the tunnel system. This thesis represents the numerical modeling of tunnel in soft ground using MIDAS software. One of the major objectives of tunnel analysis is to figure out the stability of the given design. Apart from this, a comprehensive analysis of stresses induced in the shotcrete and rock bolt are also carried out. Ground characteristics values, ground initial stresses as well as support characteristics value are the input data's for the study. After the excavation of the tunnel body, the installation of primary supports is performed and at last the stage of shotcrete hardening is analyzed. The initial stresses has a major influence on the tunnel behavior, since stability evaluation of tunnel is conducted by changing the Coefficient of lateral earth pressure. Lastly, behavior of tunnel due to the presence of structures near tunnel is also evaluated.

**KEYWORDS:** Tunnels, MIDAS, Deformed mesh, Finite Element Modeling.

---

### 1. INTRODUCTION

A tunnel is an underground passage, dug through the surrounding soil/earth/rock and enclosed except for entrance and exit, commonly at each end. A pipe line is not a tunnel, though some recent tunnels have used immersed tube construction techniques rather than traditional tunnel boring methods. With an increasing population and expanding urban areas, there is a need for tunnels that are used for efficient transportation, water supply, sewage disposal and communications. A tunnel may be for foot or vehicular road traffic, for rail traffic, or for a canal. The central portions of a rapid transit network are usually in tunnel. Some tunnels are aqueducts to supply water for consumption or for hydroelectric stations or are sewers. Utility tunnels are used for routing steam, chilled water, electrical power or telecommunication cables, as well as connecting buildings for convenient passage of people and equipment. Secret tunnels are built for military purposes, or by civilians for smugglings of weapons, contraband, or people. Special tunnels, such as wildlife crossings, are built to allow wildlife to cross human-made barriers safely. Tunnels can be connected together in tunnel networks. A tunnel is relatively long and narrow; the length is often much greater than twice the diameter, although similar shorter excavations can be constructed, such as cross passages between tunnels. In urban areas, tunneling is often out in soft ground and this process inevitably leads to a change in stress state of the ground with associated changes in strains and displacements, which could potentially result in damage to existing surface and subsurface structures. In low permeability soils, a change in stress state induces excess pore pressures that, in the long-term, dissipate into a new equilibrium regime leading to further ground displacement and complex loading on tunnel supports. As part of the planning process, knowledge of the magnitudes of these ground displacements is often required. Finite element analysis can be used for predicting these ground movements and ground loading on the tunnel lining.

#### 1.1 Importance of tunnel analysis

A number of collapses of shallow tunnels excavated in soils with 'manual' or mechanical methods have occurred in the past due to inadequate support considered for the openings or other unforeseen conditions in the ground. Economic yet safe and flexible designs of tunnel supports can be achieved with better understanding of the relationships that govern the stability of shallow tunnels, especially the relationship between support

pressure, soil cover above the tunnel, size of the tunnel and the mechanical strength of the ground hosting the tunnel. Such understanding could be gained by availability of simple analytical relationships that allow examination of the dependence of variables involved in the problem. These analytical relationships can allow implementation of probabilistic analyses for computing probability of failure (and therefore reliability of designs) for tunnel fronts and sections, as it is current practice for other geotechnical structures, such as natural and man-made slopes (including embankments). The effects are expressed in terms of surface displacement and soil stress change caused by tunneling. The subsoil stresses undergo three phases of change. At these phases, the loading steps of the tunnel construction are predicted using the 2-D finite element analysis. Ground movement and construction influence are obtained by the numerical model. **Mohammad Hamed et.al, (2012)** studied

Numerical analysis of tunnel using PLAXIS. When the tunnel has been made, stability is an important factor due to advancing cycle and cost especially in soil or weak rock. Study on behavior of surrounding soil and rock at this condition is a great challenging of engineers section, recent development in the field of Finite Element method have led to a renewed interest in the analyses of tunnel stability and prediction of ground movement. The merit is that we can have an appropriate estimation of behavior of soil or rock before drilling and to find out which part of tunnel is under a major settlement risk, especially when the tunnel is drilled into multi layer soils. **Mahdi, Shariatmadari N, (2013)** studied the analysis of Tehran metro tunnel construction An important aspect of planning for shallow tunnelling under urban areas is the determination of likely surface movements and interaction with existing structures. Back analysis of built tunnels that their settlements magnitude is available, could aid the designers to have a more accuracy in future projects. In this paper, one single Tehran Metro Tunnel (at west of Hor square, Jang University Street) was selected. At first, surface settlements of this tunnel were measured in situ. Then this tunnel was modeled using the commercial finite difference software FLAC-3D. **Houari et.al, (2014)** conducted Numerical stimulation of mechanical response of the tunnels in the saturated soils by PLAXIS. The forecast of settlement and movements caused by tunneling represents a significant challenge of technology. The evaluation of these movements is indeed of primary importance in order to prevent them. The methods of calculation making it possible to evaluate displacements and deformations in the ground due to tunneling give only one approximation of the true amplitudes of the movements in the ground. It is one of the assets of the Finite Element Method (FEM) which makes it possible a priori to treat configurations more complex and closer to reality. **Masoud Mirmohammad Sadeghi, et.al, (2014)** analyzed the Effect of soil-structural model selection on generated stress in tunnel. In recent years, with developing of laboratory and Tunnelling equipments and numerical analysis of software, the anticipation of tunnels structural treatment in short and long term has performed. Effects of Soil structural Models Selection on generated stresses in Tunnel with Mohr-Coulomb and Hardening- Soil Models has assessed. **Carranza-Torres, Reich Saftner (2016)** studied the Stability of shallow circular tunnels in soils using analytical and numerical models. The paper revisits a classical problem of geotechnical engineering involving the stability of the shallow circular tunnels excavated in frictional cohesive materials. The problem is of practical interest since, among others, it allows establishing conditions of stability for the front of tunnels in soil excavated manually or using mechanized method.

### 1.2 Objectives of the proposed work

The main objective of proposed work is to establish an appropriate soil model for a single shallow tunnel in soft ground. And also to evaluate degree of displacement induced in adjacent structure and soil layer during tunneling operation.

## 2. METHODOLOGY

Work Flow of Tunnel Analysis :

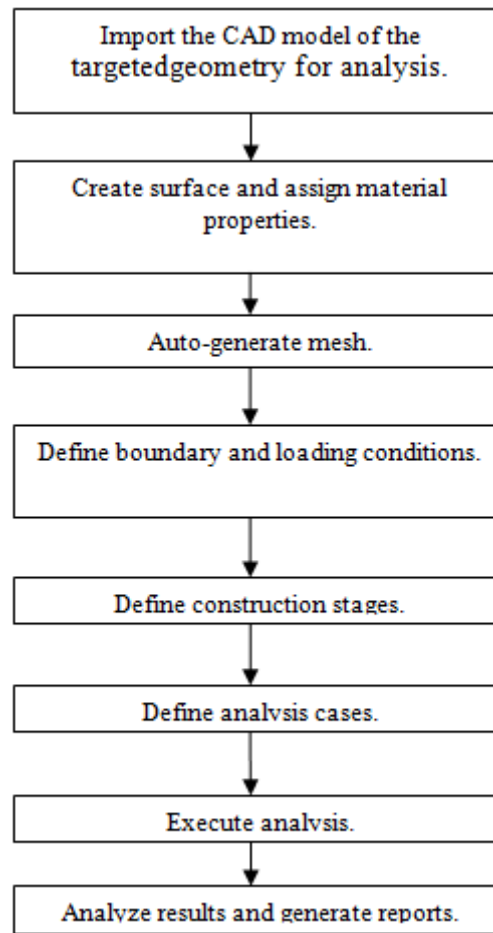

### 2.1 MIDAS / GTS software:

Midas/ GTS NX is a comprehensive geotechnical finite element software package that is well equipped to handle the wide range of 2-Dimensional and 3-Dimensional analysis of deformations and stability of most of soil structures in various geotechnical applications including : Deep Foundations, Complex Tunnel systems, Seepage Analysis, Consolidation Analysis, Embankment Design, Dynamic and slope stability analysis. Types of soil models available in the MIDAS software are: Linear Elastic, Tresca, Von Mises, Mohr-coulomb, Drucker-prager, Strain softening, Soft soil creep etc. GTS NX also offers an advanced user friendly modelling platform that enables different levels of precision and efficiency.

- Tunnel analysis using MIDAS/ GTS : GTS NX is fully equipped to model and analyze each phase of tunnel construction, including a simulation of the excavation itself and the installation of supports. Shield TBM analysis can be performed to obtain maximum axial forces, shear forces, bending moments and radial displacements of the tunnel for each phase of the construction sequence. GTS NX also enables you perform analyses of various types of tunnel linings such as unsupported rock, concrete, and unreinforced concrete systems. You can also take multiple load cases into account such as vertical stresses in soil and horizontal pressures on the tunnel surface. Afterwards you can run the analysis to calculate the resulting forces and moments for each element of the lining.

### 2.2 Geometry of the model :

( Figure1 ) represents the geometry of the tunnel projects. The tunnel is intended to be constructed on a single sand layer. The model is considered as Mohr-coulomb model and the model behaviour is chosen as drained behaviour. The material properties of the soil required for this study is shown in Table 1 and they are derived from previous literature (ref. Journal). The water table is located at a depth of 10m from the surface. Primary

support features like anchors and shotcrete lining are provided, whose properties are shown in Table 2 and Table 3 and behaviour is assumed as elastic. A pile foundation with 0.25m diameter is also given , properties are defined in Table 4.

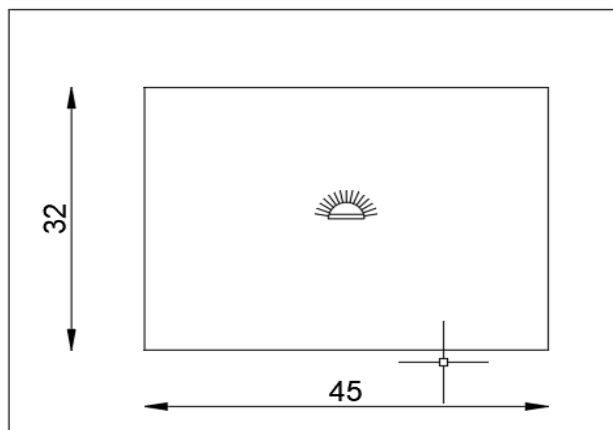

Fig 1 : Geometry of the tunnel project.

Table 1 : Characteristics of the soil

SOIL PROPERTIES	
Type of model	Mohr - Coulomb
Type of behaviour	Drained
Soil weight above phr.level (kN/m <sup>3</sup> )	17
Soil weight below phr.level (kN/m <sup>3</sup> )	21
Young modulus (kN/m <sup>2</sup> .)	1.2 × 10 <sup>5</sup>
Poisson's ratio	0.3
Cohesion (kN/m <sup>2</sup> .)	1
Angle of friction ( degree)	33
Angle of dilatancy (degree)	3

Table 2 : Lining Properties

LINING PROPERTIES	
Type of behaviour	Elastic
Elastic modulus (kN/m <sup>2</sup> )	0.5 × 10 <sup>7</sup>
Unit weight (kN/m <sup>3</sup> )	24
Equivalent size (m)	0.35 × 1
Weight ( kN)	8.4
Poisson's ratio	0.15

Table 3 : Mechanical Properties of Anchors

Type of behaviour	Elastic modulus (kN/m <sup>2</sup> )	Unit weight (kN/m <sup>3</sup> )	Diameter (m)
Elastic	2.1 × 10 <sup>8</sup>	78	0.025

Table 4 : Foundation Properties

Type of behaviour	Elastic modulus (kN/m <sup>2</sup> )	Unit weight (kN/m <sup>3</sup> )	Diameter (m)
Elastic	2 × 10 <sup>6</sup>	24	0.25

### 2.3 2D Finite Element Mesh :

Following are the steps involved in finite element mesh development.

Step 1 : Analysis Case setting.

- Step 2 : Define Ground and Structural Materials.
- Step 3 : Define Properties.
- Step 4 : Modelling.

Fig 2 shows the generated 2D finite element mesh. In this study an element with nodes are employed. The element consist of 2606 nodes. There are relatively regular elements of lower size around the tunnel.

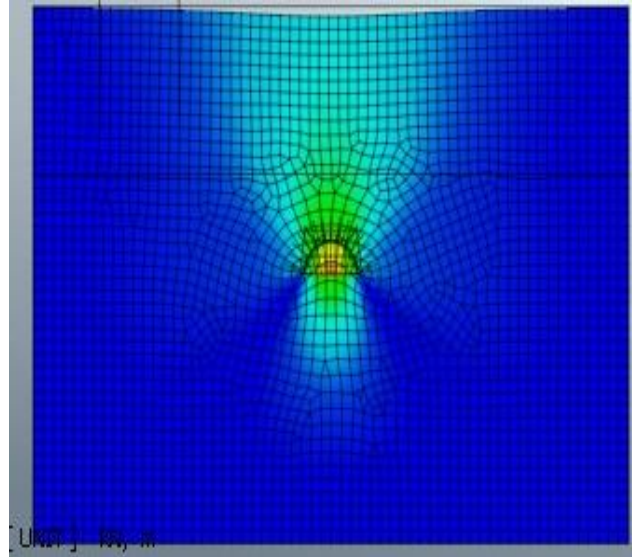

Fig 2 : 2D Finite element mesh

### 3. ANALYSIS AND DISCUSSION

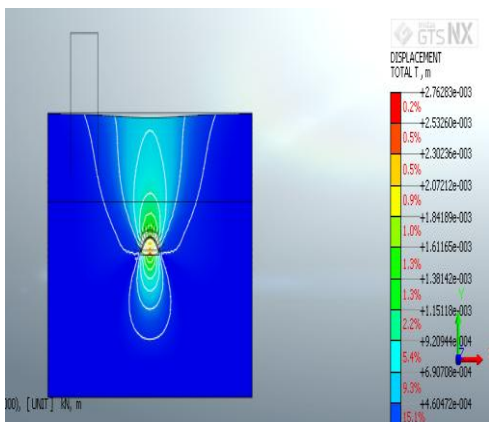

Fig 3 : Total displacement.

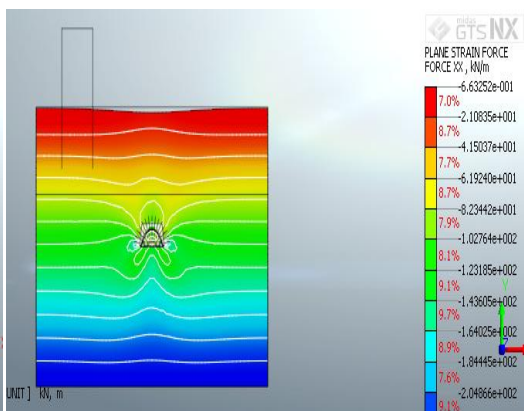

Fig 4 : Plane strain force

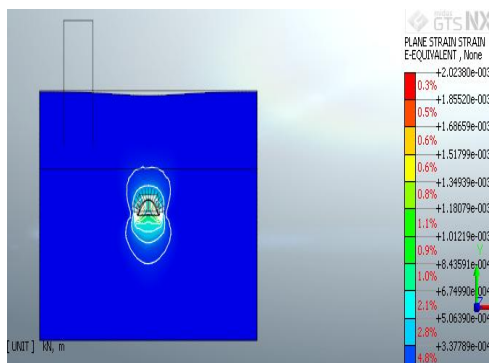

Fig 6 : Strain equivalent.

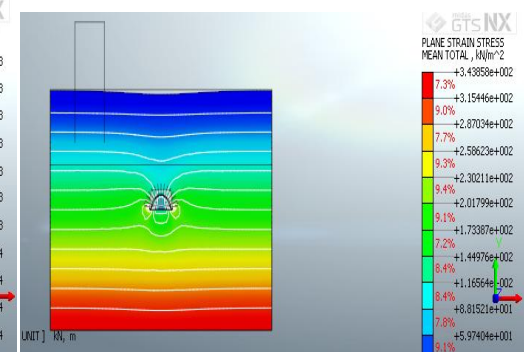

Fig 7 : Stress

Table 4 shows the variation of displacement with change in tunnel diameter.

**Table 4 : Variation of displacement with tunnel diameter**

Diameter (m)	Displacement (mm)
4	12.65
5	13.947
6	7.75

Table 5 shows the variation of plane strain forces with change in tunnel diameter.

**Table 5 : Variation of plane strain force with tunnel diameter**

Diameter (m)	Plane strain force (kN/m)
4	70.786
5	72.057
6	51.17

Table 6 shows the effect of tunnel diameter on the Plane strain strain.

**Table 6 : Effect of tunnel diameter on Plane strain strain**

Diameter (m)	Plane strain strain
4	0.008355
5	0.011965
6	0.00643

Table 7 shows the effect of tunnel diameter on plane strain stresses.

**Table 7 : Effect of tunnel diameter on plane strain stresses**

Diameter (m)	Plane strain stress (kN/m <sup>2</sup> )
4	82.725
5	83.209
6	76.64

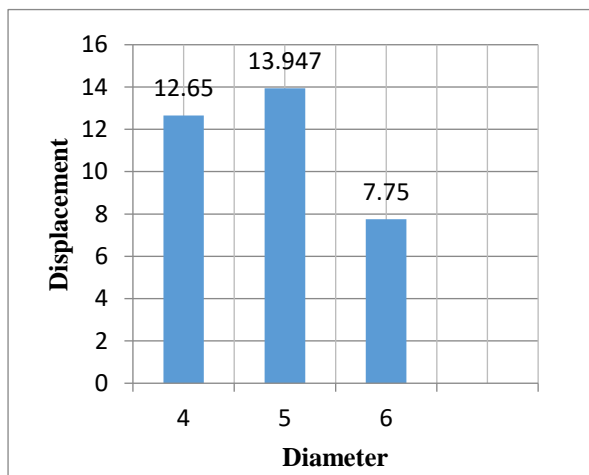

**Fig 8 : Displacement v/s Diameter**

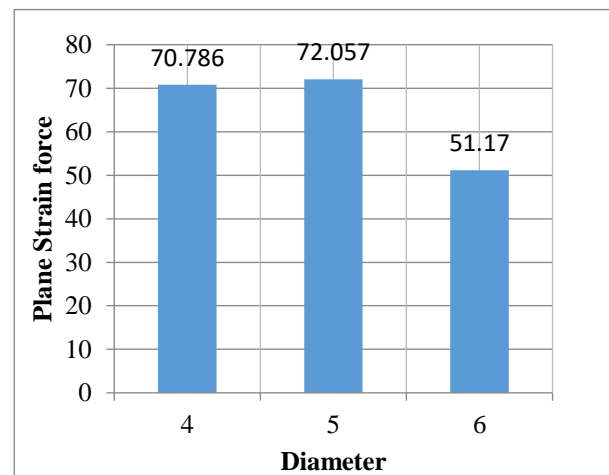

**Fig 9 : Plane strain force v/s Diameter**

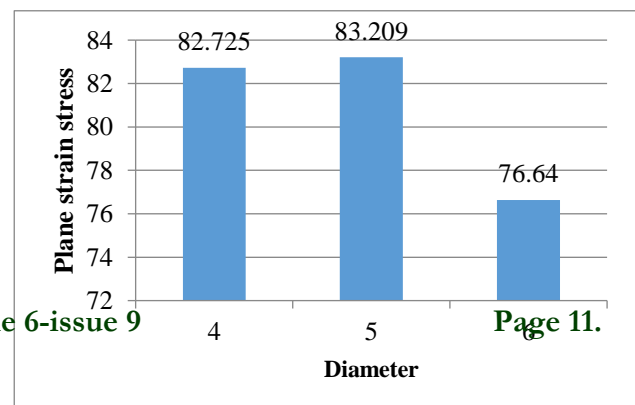

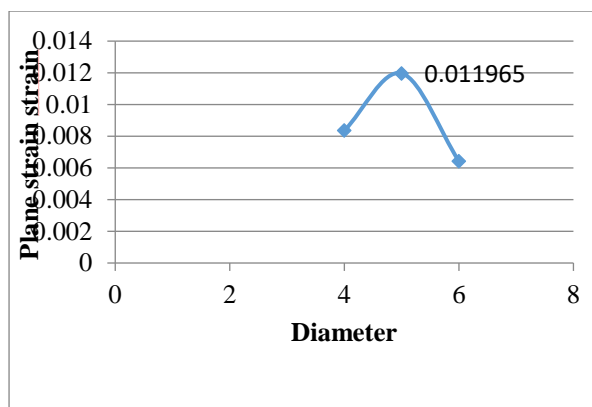

Fig 10: Plane strain strain v/s Diameter

Fig 11 : Plane strain stress v/s Diameter

#### 4. CONCLUSION

Stress variation around the tunnel is important in selection of tunnel concrete lining and amount of forces has generated in supports. A 2-D numerical model is applicable to analyze and predict the detailed performance of the tunnel system.

- The lowest displacement is obtained for tunnel with diameter 6m with a value of 7.75mm compared to other two diameters.
- Plane strain forces, strains, as well as the stresses were found to be lowest at 6m diameter tunnel.  
i.e., Force at 6m tunnel = 51.17 kN ;  
Strain = 0.00643 ; Stress = 76.64 kN/m<sup>2</sup>.

#### 5. ACKNOWLEDGEMENTS

First of all, I would like to thank the Lord Almighty for his grace and the blessings on me. It is my pleasure to place on report my deep sense of gratitude to my guide Mrs. Veena Vijayan .L , Assistant Professor, Civil Engineering Department, St.Thomas Institute For Science And Technology, Trivandrum, Kerala. It was her deep interest and guidance throughout the course of the study that made this work possible. I gratefully acknowledge her constant encouragement and valuable suggestions which have given me the confidence to pursue the study. I extend my sincere gratitude to all my friends who have constantly encouraged and supported me in my project work.

#### REFERENCES

- [1] Carranza-Torres, Reich & Saftner, Department of Civil Engineering, University of Minnesota, Duluth Campus, Minnesota, USA "Stability of shallow circular tunnels in soils using analytical and numerical models"
- [2] Fathalla M. El-Nahas Professor of Geotechnical Engineering and Foundations, Ain Shams University, Cairo, Egypt "Tunnelling and Supported Deep Excavations in the Greater Cairo".
- [3] Ground movements due to shallow tunnels in soft ground", journal of geotechnical and geoenvironmental engineering, vol 140, No.4, April 2014 Houari , Allal M and AbouBekr N.
- [4] "Numerical Simulation of the Mechanical Response of the Tunnels in the Saturated Soils by Plaxis", Jordan Journal of Civil Engineering, Volume 5, No. 1, 2011 Mazek , Almannaei "Finite element model of Cairo metro tunnel-Line 3 Performances" . Ain Shams Engineering Journal (2013) 4, 709–716.
- [5] Mahdi, Shariatmadari N "Analysis of Tehran Metro Tunnel Construction", World Academy of Science, Engineering and Technology International Journal of Civil, Architectural, Structural and Construction Engineering Vol:7 No:9, 2013
- [6] Masoud Mirmohammad Sadeghi, Saied Izadpanah, Ehsan Gharghabi, Erfan Hosseini "Effects of Soil Structural Models Selection on Generated Stresses in Tunnel", Journal of Applied Science and Agriculture.