

## Heat Transfer Enhancement Through Extended Surfaces (Fins): A Brief Overview

Amelia Walker<sup>1</sup>, Chloe Davis<sup>1</sup>, Olivia Scott<sup>2</sup>, William Brown<sup>3</sup>, and Ryan Parker<sup>\*3</sup>

<sup>1</sup> Department of Geophysics, University of California, Berkeley, USA

<sup>2</sup> Department of Physics, University of Manchester, UK

<sup>3</sup> School of Biomedical Sciences, University of Tokyo, Japan

---

### ABSTRACT

Extended Surfaces (Fins) are widely used in the engineering field for enhancement of heat transfer rate by increasing surface area with additional material attachment. In many applications like heat exchangers, economizer, cooling reactor core, electrical transformer and motors, automobile applications, rectifier, etc fins are used for better heat transfer. This paper is about an overview of various types of fins, their classification, their geometries, materials used for it, design considerations and applications with some case studies of thermal simulation and some special applications.

**Keywords:** *Extended Surface, heat transfer, pin fin, thermal simulations*

---

## I. INTRODUCTION

Whenever the available surface is found inadequate to transfer the required quantity of heat with the available temperature drop and convective heat transfer coefficient, extended surfaces or fins are used. The fins are commonly used to increase the heat transfer rate of the surface when it is not possible to increase the heat transfer rate by increasing the heat transfer coefficient on the surface or by increasing the temperature difference between the surface and the surrounding fluid. Fins are mostly used for sensible heat transfer both for heating and cooling the adjacent fluid.

## II. FINS

A fin is a surface that extends from an object to increase the rate of heat transfer to or from the environment by increasing convection. For the principle of conduction, convection, radiation of a pin configuration determines the amount of heat it transfers. Increasing the temperature difference between the fin configuration and the environment, slightly increasing the convection heat transfer coefficient, or slightly increasing the surface area of the pin configuration of the object increases the heat transfer. Sometimes it is not economical or it is not feasible to change the first two options. Adding a fin configuration to the object, however, slightly increases the surface area and can sometimes be an economical solution to heat transfer problems. Circumferential fins around the cylinder, square and rectangular shape of a motor cycle engine and fins attached to condenser tubes of a refrigerator are a few familiar examples. Only when there is a temperature difference, flows faster when this difference is higher. Always flows from high to low temperature, is greater with greater surface area.

## III. MODES OF HEAT TRANSFER

Heat, by definition, is the energy in transit due to temperature difference. Whenever the process of pin configuration exists, a temperature difference in a medium state or between media, heat flow must. Different types of pin configuration of heat transfer processes are called modes. When a temperature gradient of pin configuration exists in a stationary medium, which may be a solid or a fluid to the concern, heat flows under the law of conduction and convection heat transfer. On the other hand, if the temperature gradient exists between the pin surface and a moving fluid, the process we use is termed convection. The third mode of heat transfer is termed radiation; it depends on the pin and it needs no medium to transfer heat since it is driven by electromagnetic waves emitted from all pin surfaces of finite temperature, so there is a net heat transfer by conduction and radiation between two surfaces at different temperatures.

## IV. CLASSIFICATION

By thermal analysis on the fins, we can predict the temperature profile and rate of heat dissipation for various types of fin. We know that, by increasing the surface area of pin configuration, we can increase the heat dissipation rate of this process. For designing such a large complex systems is very difficult. Therefore fins are provided on the surface of the system to increase heat transfer. Fins of the circular, square and rectangular surfaces that extended from a pin configuration to increase the rate of heat transfer from the environment by increasing convection. For this principle of conduction, convection, radiation of a fin configuration determines the amount of heat and its transfers. Fins can be classified in different manners

**A. As per condition of fluid exposed:**

**1. Wet fins:**

As condensation of water vapour takes place over the fin surface, fins used for cooling and dehumidification is often termed as "wet fins".

**2. Dry fins:**

If condensation of water vapour does not takes place over the fin surface then fins are termed as "dry fins".

**B. As per geometry of the fins:**

**1. Straight fin with uniform cross section:**

There are various types of geometrical shape fins included under this type

**i. Rectangular fins:**

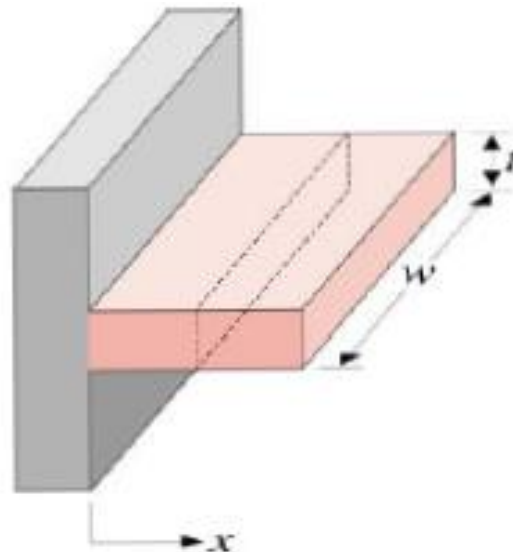

Figure : 1.<sup>[4]</sup> Rectangular fin is shown in figure:1

**ii. Circular fins (pin fin with uniform cross section) :**

Circular fin is shown in figure.

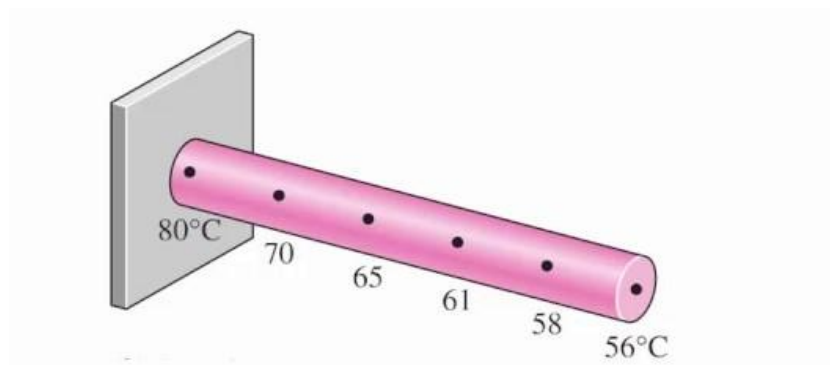

Figure : 2.

**iii. Triangular fins :**

Triangular fin is shown in figure.

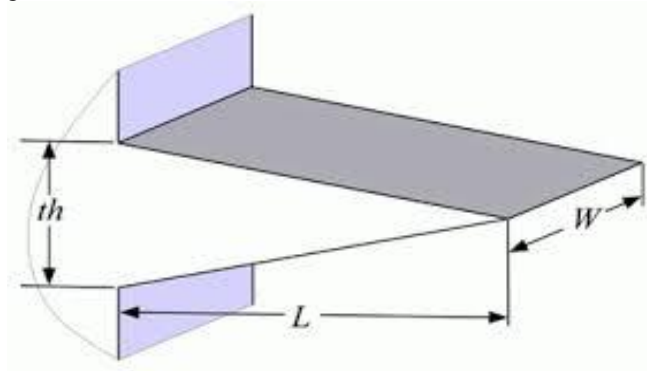

Figure :3

**iv. Square fins:**

Square fin is shown in figure of thermal simulation (figure 8).

**2. Straight fin with non uniform cross section:**

There are many types of fins which does not have proper geometrical shape but they have very good heat transfer rate. So, different kinds of non uniform cross section fins are also used.

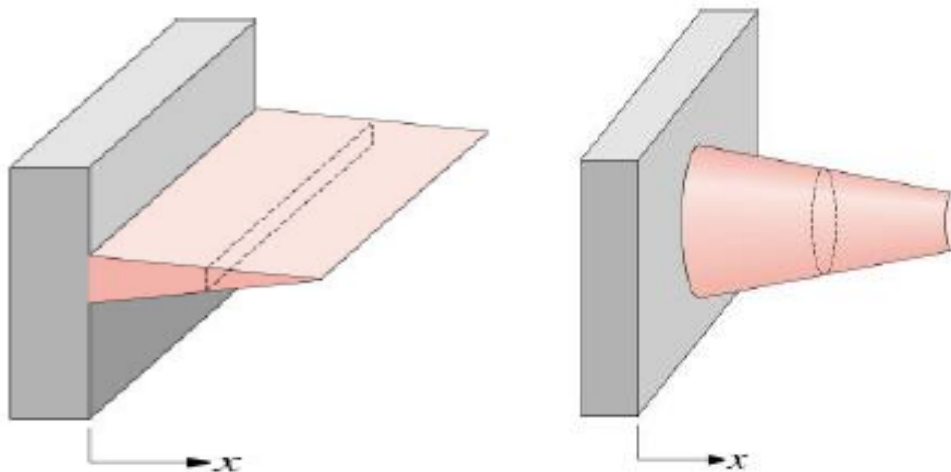

Figure: 4.<sup>[4]</sup>

**3. Annular pin:**

Annular fin is shown in figure 5.

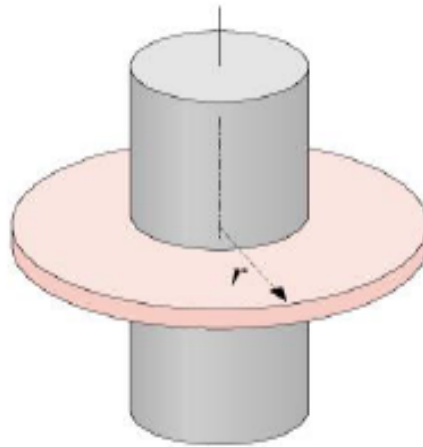

Figure: 5<sup>[4]</sup>.

**4. Pin fin with non uniform cross section:**  
This type of fin is shown in figure.

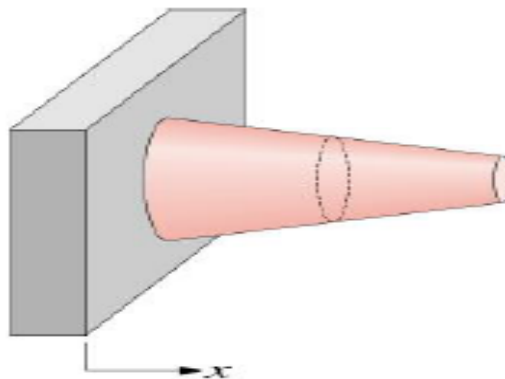

Figure : 6.<sup>[4]</sup>

## V. MATERIALS USED FOR MAKING FINS

The material used for the fin construction is discussed here.

### Copper and its alloy:

Copper has the thermally characteristics high compared to the Al, brass. It includes corrosion resistance, bio fouling resistance, maximum allowable stress and internal pressure, creep rupture, fatigue strength, thermal expansion, alloy ability, ease of fabrication and ease of joining.<sup>[1]</sup>

### Aluminum and its alloy:

Usually, Aluminum is referred for fin design. It has the ability to emit heat effectively. Because of its light weight quality it is easier to install. It is noncorrosive. Aluminium2014, Aluminium6061, Aluminium6013 are various alloys of aluminum.

**Brass:**

Brass belongs to the copper zinc alloy. It can be recycled. Aluminum, lead and silicon blended with brass to enhance the corrosion resistance. Problems occur is season cracking in brass. Alpha, beta, gamma and white brass are its types.<sup>[1]</sup>

**VI. SPECIAL MODIFICATION IN FINS**

Fins are surface extensions widely used in different types of heat exchangers for increasing the rate of heat transfer among a solid surface and surrounding fluid. Often geometrically modified fins are incorporated, which besides increasing the surface area density of the heat exchanger, also improve the convection heat transfer coefficient <sup>[1]</sup>. Some examples of such enhanced surface compact cores include Offset-strip fins, Louvered fins, Wavy fins, Plain fins and Pin fins. Fins promote boundary layer separation and restarting of the boundary layer increases the heat transfer rate. Plate fin or tube and plate fin type of compact heat exchangers, where the finned surfaces provide a very large surface area density, are used increasingly in many automotive, waste heat recovery, refrigeration and air conditioning, cryogenic, propulsion system and other heat recuperative applications, a variety of finned surfaces typically used include plate fins, pin fins, offset strip fins, louvered fins and wavy fins.<sup>[2]</sup>

**Plate Fins:**

This type of extended surface heat exchanger has corrugated fins mostly of triangular or rectangular cross-sections sandwiched between the parallel plates as shown in Figure.

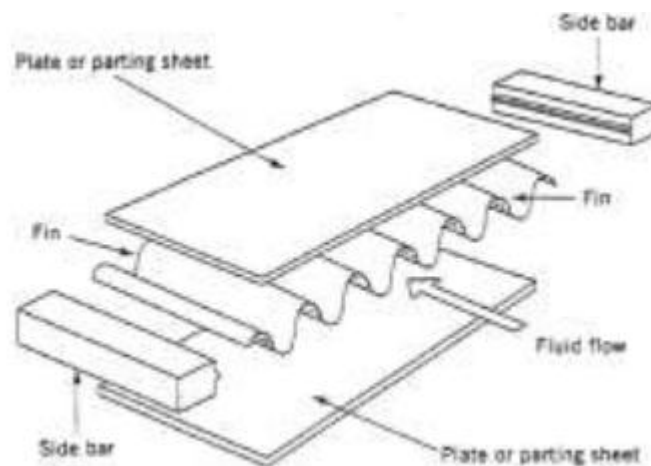

*Figure:7, Basic components of a plate-fin heat exchanger [2]*

The fins may also be incorporated in a flat tube with rounded corners. The parting sheet is usually replaced by a flat tube in the case of liquid or phase change fluid flows on the other side. Fins are die or roll formed and is attached to the plates by brazing, soldering, adhesive bonding, welding, mechanical fit, or extrusion. Plate-fins are categorized as: (1) plain i.e. uncut and straight fins, such as plain triangular and rectangular fins, (2) plain but wavy fins, and (3) interrupted fins etc

**Pin Fins:**

Over the years pin fins have been used as elements for effective heat transfer in various applications where space and weight are important constraints such as in the power plant industry for cooling of gas turbine blades, in the electronics industry for cooling of electronic components and recently also in the hot water boilers of central heating systems. Thus the thermal and fluid dynamic characteristics of flow over pin fins have been the interest of numerous investigators. The major advantage of pin fins is their higher heat transfer coefficient compared with that of other high performance fins. However, this provides a cross section of pins which is of the same order of magnitude as the cross-section of other fin types. Taking into account the dimensions of strip, wavy or louvered fins (~1mm), it

comes out that a reasonable application of pins in heat Exchangers applied in the air conditioning and automobile industries can be expected with pins of  $d < 0.5$  mm.

**Wavy Fins:**

Wavy fins are widely used in the air conditioning, refrigeration and process industries. Generally, heat exchanger containing wavy fins can be encountered in gas to gas and liquid to gas heat transfer applications. In the practical application of wavy fins there are two type often utilized, namely herringbone and smooth wavy. Heat transfer enhancement in wavy fin heat exchangers is achieved by extension of the flow passage and breaking of the boundary layer owing to periodic changes of the flow direction and eventual flow impingement on to the neighboring fin surface.

**Offset Strip Fins:**

Offset strip fins are one of the most widely used elements for heat transfer enhancement in the aircrafts, cryogenics, and many other industries that do not require mass production. Offset strip fin surfaces belongs to the highest heat transfer performance surfaces. Their heat transfer coefficient is 1.5 to 4 times those of plain fins.

**Louvered Fins:**

In compact heat exchanger very important forms of elements for heat transfer enhancement are single and multi-louvered Fins. These are basically used in radiators, heaters, evaporators and condensers in the automotive industry, where the space and weight are two major constraints. The availability of high-speed production techniques, consequently being less expensive than other interrupted fins, is an additional reason for their wide usage. By providing multiple edge and flow deflection and partial flow impingement, they are associated with higher heat transfer coefficients than those for offset strip fins. Although the friction factor increase is greater than the heat transfer increase, the heat exchangers can be designed for higher heat transfer and the same pressure drop compared with those with offset strip fins by proper selection of the exchanger frontal area, core depth, and fin density. Louvered fin geometry can be considered as a combination of wavy and strip fin geometry.<sup>[2]</sup>

**Comparison of Extended Surfaces (Fins)<sup>[2]</sup>:**

Sr. No.	Types of extended surfaces (fins)	Heat transfer coefficient	Enhancement achieved by	Application
1.	Plate fins	Decrease the fin density increase the heat transfer coefficient	a. Provide a very large surface area that help evenly distribute heat b. The fins can be waffled or ripped for greater efficiency	Air pre-heater, transformer oil coolers, air cooled heat exchanger
2.	Pin fins	Affected by high friction factors of pin fins	a. Optimal pin length and cross – section	In the power plant industry, in the electronics industry, in the hot water boilers of central heating systems.
3.	Wavy fins	Depends on fin pitch, wave length, wave depth and fin thickness	Breaking of boundary layer Extension of the flow passage Eventual flow impingement	Air conditioning, Refrigeration, and process industries
4.	Offset strip fins	1.5 to 4times of plain fins	Flow passage broken	Aircraft, cryogenic and in

			into small sections Convective heat transfer	small industries
5.	Louvered fins	Higher than offset strip fin	By providing multiple edge partial flow impingement	Radiators, heaters, evaporators and condenser

**Fins Performance Parameters:**

In previous sections, it was pointed that for the enhancement of convective heat transfer, fins provide the most effective elements. Regardless of the fin geometry, an exact theoretical analysis of their heat transfer mode is in most practical cases not possible. The large variety of fins used up to now can be grouped as longitudinal, radial and in pin fins. There are long list of assumptions for analysis for fins some of these assumptions, such as  
 The thermal conductivity of the fin material is constant.  
 The heat transfer coefficient is the same over the entire fin surface  
 The temperature at the base of the fin is uniform.  
 The heat transfer through the tip of the fin is negligible compared with the heat leaving its lateral surface.  
 The fin thickness is so small compared with its length that temperature gradients normal to the surface may be neglected.

**VII. EFFICIENCY AND EFFECTIVENESS OF FINS**

**Efficiency of fin:**

The efficiency of the fin is defined as the ration of the actual heat transfer to the maximum heat transfer by fin, if entire fin area were at base temperature.

$$\eta = \frac{\text{actual heat transfer rate from the fin}}{\text{heat dissipated if the whole surface of the fin were maintained at the base temperature}}$$

$$\eta = \frac{\sqrt{(phkAc)}(t_0 - t_a)}{h(pl)(t_0 - t_a)}$$

η= efficiency;

h=convective heat transfer coefficient of material;

k=thermal conductivity (constant) of material;

l=length of fin;

Ac=cross-sectional area;

P=perimeter of fin;

$t_0$  = temperature at the base of the fin;

$t_a$  = temperature of ambient / surrounding fluid;

**Effectiveness of the fin:**

Effectiveness of the fin is the fin heat transfer rate (heat dissipation with a fin) to the heat transfer rate that would exist without a fin.

$$\epsilon = \frac{Q_{with\ fin}}{Q_{without\ fin}}$$

$$\epsilon = \frac{\sqrt{PhkAc} (t_0 - t_a)}{hAc(t_0 - t_a)}$$

**Mathematical modeling for fin heat transfer:**

Here various fin cases are mentioned based on tip conditions, temperature distribution and fin heat transfer equations are given. Table shown below is taken from NPTEL students slide (module: 3)<sup>[9]</sup>.

Case	Tip Condition	Temp. Distribution	Fin heat transfer
A	Convection heat transfer: $h\theta(L)=-k(d\theta/dx)_{x=L}$	$\frac{\cosh m(L-x) + (h/mk) \sinh m(L-x)}{\cosh mL + (h/mk) \sinh mL}$	$M\theta_0 \frac{\sinh mL + (h/mk) \cosh mL}{\cosh mL + (h/mk) \sinh mL}$
B	Adiabatic $(d\theta/dx)_{x=L}=0$	$\frac{\cosh m(L-x)}{\cosh mL}$	$M\theta_0 \tanh mL$
C	Given temperature: $\theta(L)=\theta_L$	$\frac{(\theta_L/\theta_b) \sinh m(L-x) + \sinh m(L-x)}{\sinh mL}$	$M\theta_0 \frac{(\cosh mL - \theta_L/\theta_b)}{\sinh mL}$
D	Infinitely long fin $\theta(L)=0$	$e^{-mx}$	$M\theta_0$

**Thermal simulation of fins:**

The heat transfer performance of fin is analyzed by ANSYS workbench for the design of fin with various design configuration such as cylindrical configuration, square configuration and rectangular configuration. The heat transfer performance of fin with same base temperature having various geometries is compared. We also performed thermal analysis of different materials. Aluminum was used as the base metal for the fin material and for various configurations. Fin of various configuration are design with the help of CATIA V5R16 software Analysis of fin performance done through the software ANSY 15.0, while analysis of different materials is done through ANSY 16.0. On comparison, rectangular configuration provides the greatest heat transfer than that of other configurations having the same volume. The effectiveness of rectangular fin is greater as compare to other configuration of fin. The maximum temperature will be at the source and the minimum temperature will be at the end of the fin. The temperature gradually decreases from one end to other end based on the given heat transfer coefficient

**VIII. ANALYSIS IN ANSYS WORKBENCH**

All the 3D models of the different fin configurations (circular, rectangular, square) are imported to ANSYS WORKBENCH 15.0 for meshing and steady state thermal analysis.

ANSYS stands for Analysis System. ANSYS Mechanical is a finite element analysis tool for structural analysis, including linear, nonlinear and dynamic studies. This computer simulation product provides finite elements to model behavior, and supports material models and equation solvers for a wide range of mechanical design problems.

ANSYS provide a cost effective way to explore the performance of products or processes in a virtual environment. This type of product development is termed virtual prototyping. With virtual prototyping techniques, users can iterate various scenarios to optimize the product long before the manufacturing is started. This enables reduction in the level of risk, and in the cost of ineffective designs.

**1. Thermal analysis of fins with different design configuration:**

**Calculation**

**1 Circular Fin Configuration:** Diameter (d) = 0.023 m, Length (l) = 0.1 m,

**2 Square Fin Configuration:** Side (a) = 0.02m, Height (h) = 0.1m

**3 Rectangular Fin Configuration:** Side (l) = 0.04m, height (b) = 0.01m,

FIN CONFIGURATION	VOLUME
CIRCULAR	$4.15 \times 10^{-5} \text{ m}^3$
SQUARE	$4 \times 10^{-5} \text{ m}^3$
RECTANGULAR	$4 \times 10^{-5} \text{ m}^3$

**Design of Circular, Square & Rectangular Fin Configuration<sup>[4]</sup>:**

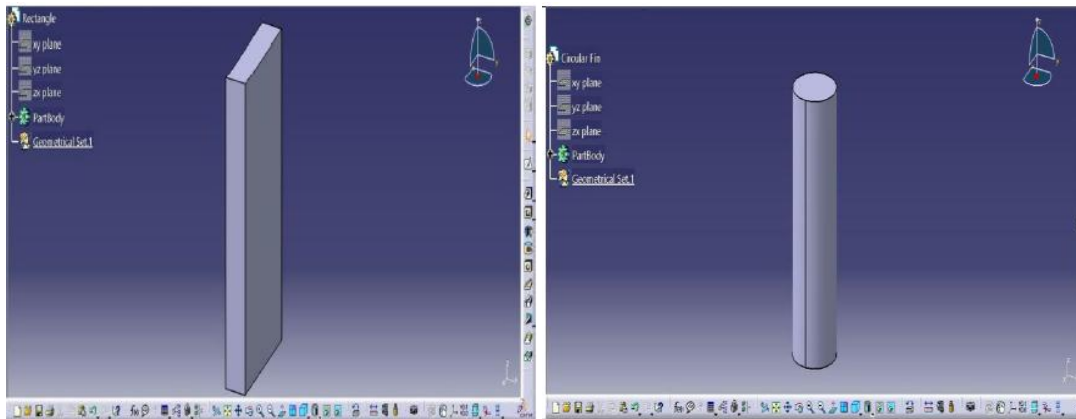

Design of rectangular, circular and square fins in CATIA V5R16 software.

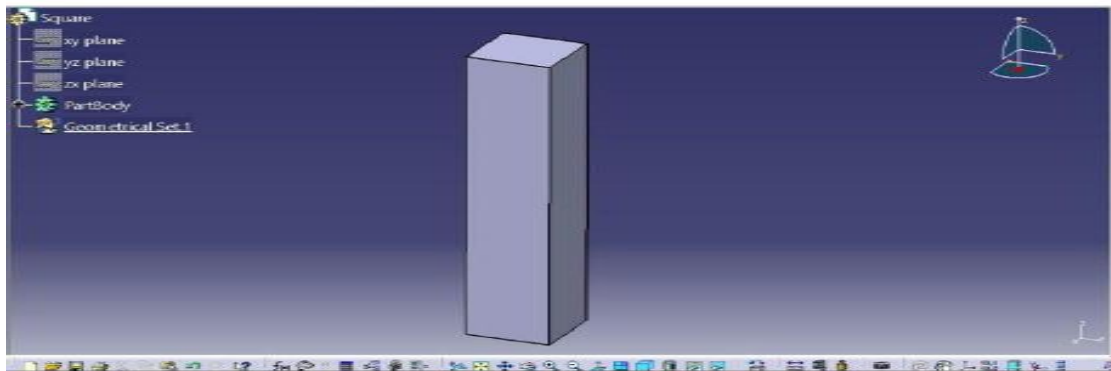

Figure: 8.

**Meshed models in ANSYS<sup>[4]</sup>:**

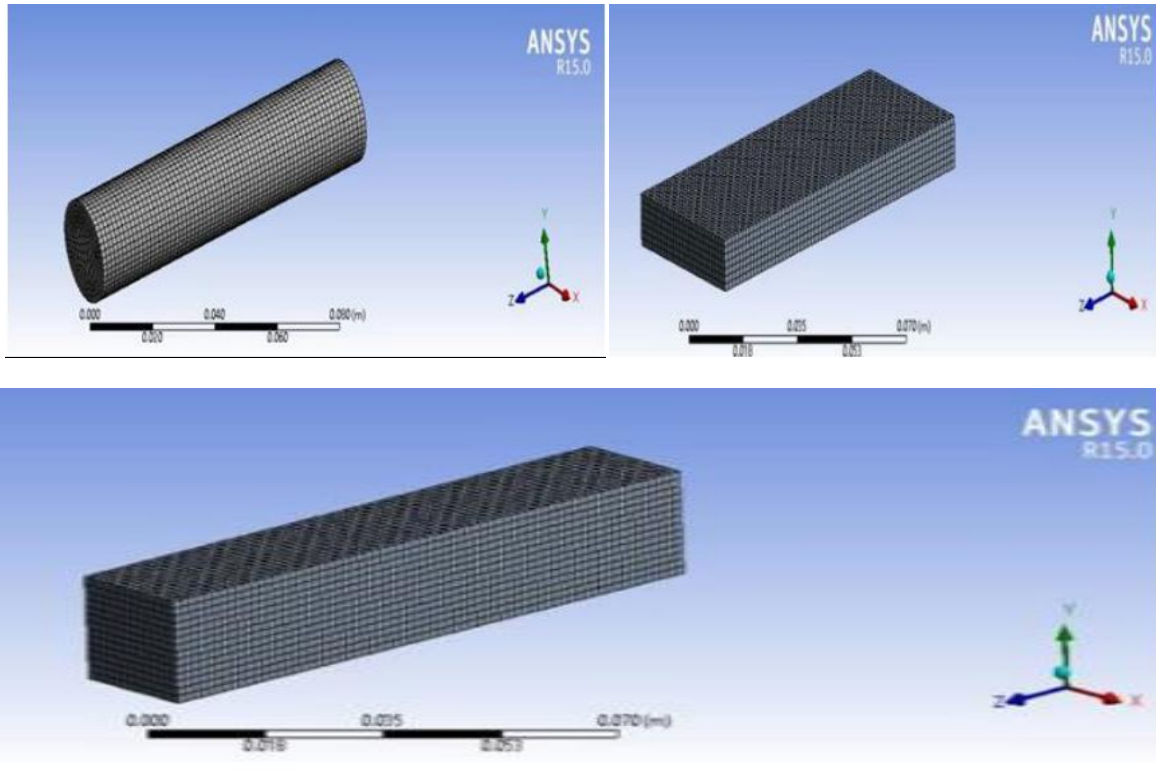
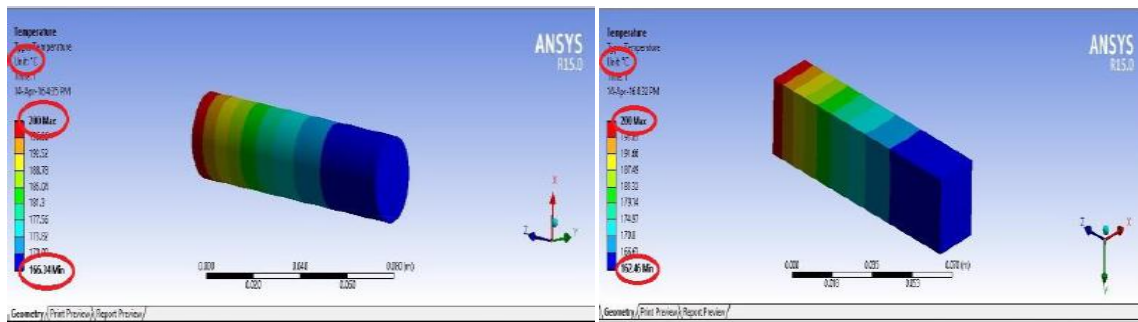
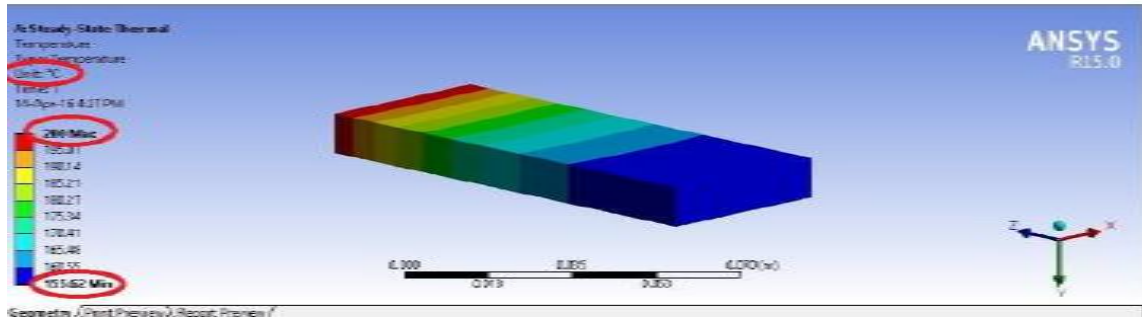

Figure: 9.

Steady state thermal analysis<sup>[4]</sup>:



Thermal simulation of circular and square fin



Thermal simulation of rectangular fin, figure: 10.

FIN CONFIGURATION	MAXIMUM TEMPRATURE	MINIMUM TEMPRATURE
Circular	200°C	166.34°C
Square	200°C	162.46°C
Rectangular	200°C	155.62°C

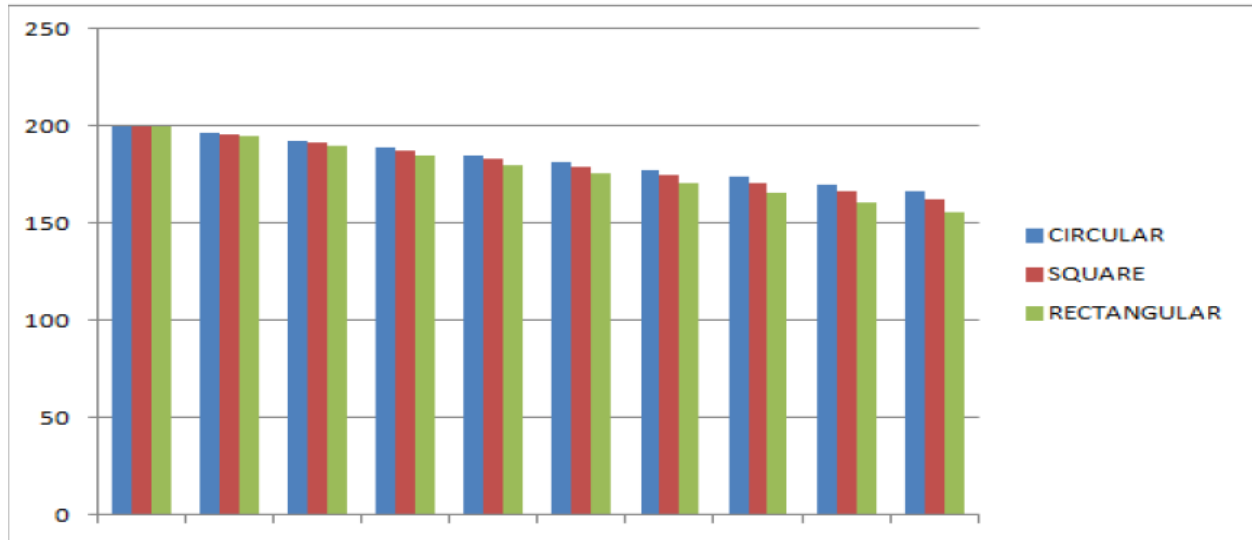

Figure: 11.

The use of fin (extended surface), provide efficient heat transfer. Heat transfer through fin of rectangular configuration is higher than that of other fin configurations. Temperature at the end of fin with rectangular configuration is minimum, as compare to fin with other types of configurations. The effectiveness of fin with rectangular configuration is greater than other configurations. Choosing the optimum size fin of rectangular configuration will reduce the cost for heat transfer process and also increase the rate of heat transfer.

2. **Temperature Distribution for different materials<sup>[7]</sup>:**

We used circular prototype of circular pin fin with different materials.

**Temperature Distribution for Aluminium<sup>[7]</sup>**

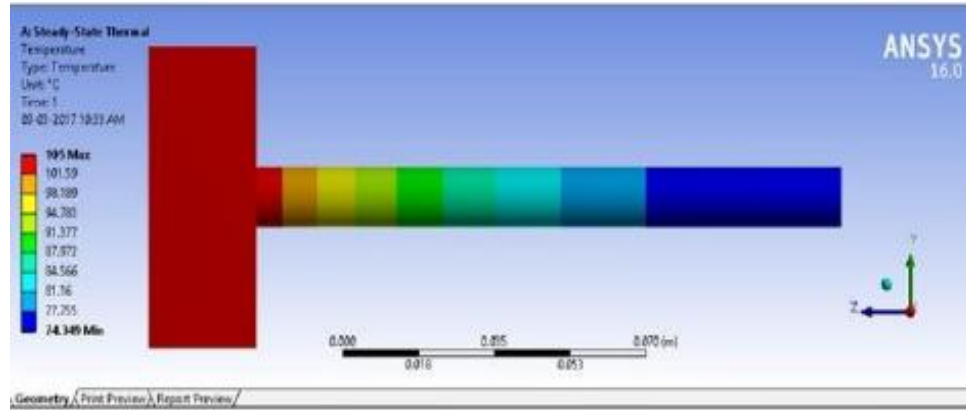

Figure: 12.

Temperature Distribution for Copper<sup>[7]</sup>:

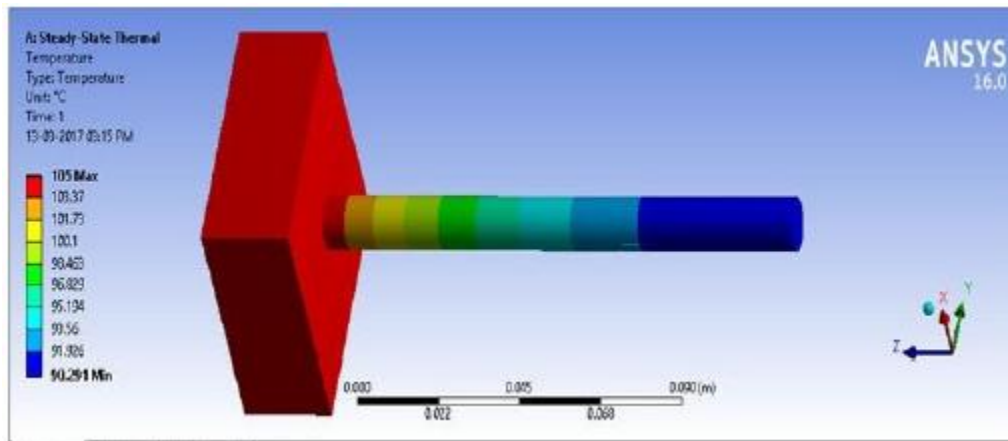

Figure: 13.

Temperature Distribution for Brass<sup>[7]</sup>

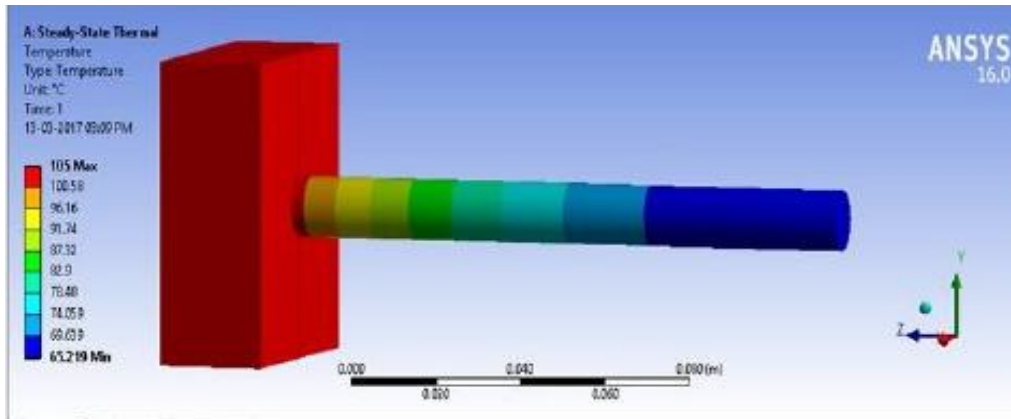

Figure 14.

Temperature Distribution for Stainless Steel<sup>[7]</sup>

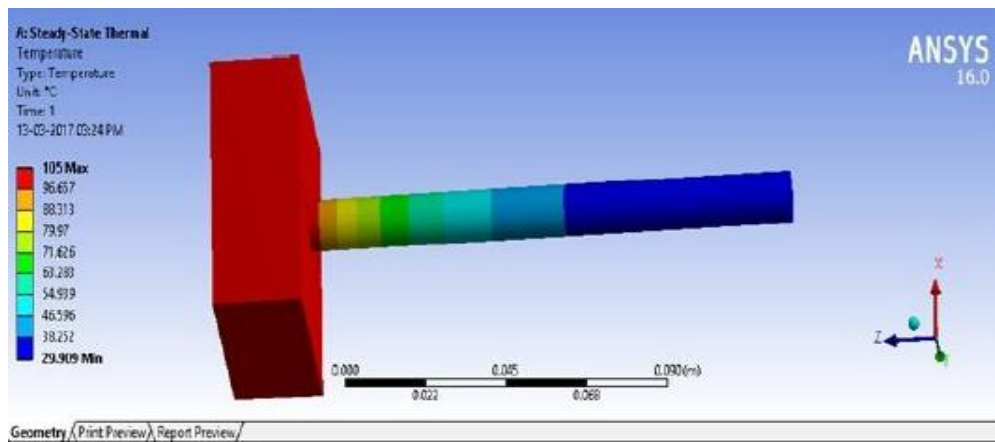

Figure 15.

As shown in above figures, thermal simulation of different materials like copper, aluminium, brass and stainless steel with circular cross section fin.

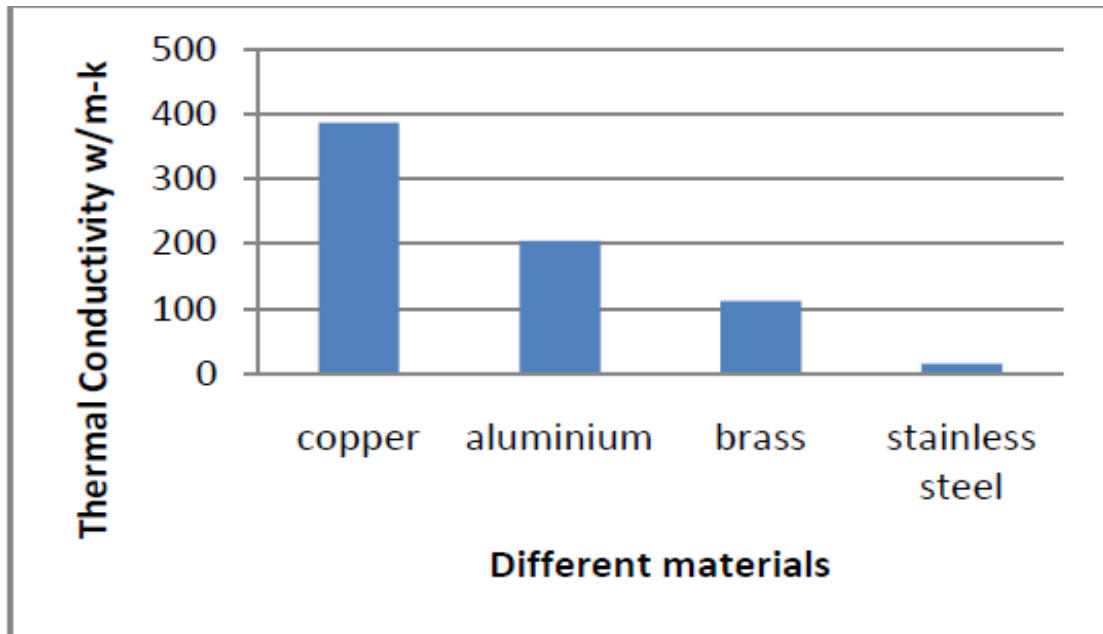

Figure: 16. [7]

From the above temperature distribution analysis of different materials copper have highest heat sink performance than the other materials, but aluminium heat sinks are often capable of dissipating the heat, because of its lower weight and lower cost than copper.

**IX. SPECIAL APPLICATIONS OF FINS:**

**Cooling Of Electronic Equipments**

High heat flux of electronic devices, e.g. projector, LED, high power chip, etc., require efficient cooling methods for heat dissipation in a limited region. It means maintaining a small heat source at an acceptable temperature. This resulted in inevitable challenges in the field of thermal management of electronics to maintain the desirable operating temperature.

Fins tend to increase the surface area of any electronic equipment body & as air flows through it, It takes away the heat of equipment through it. So, Simply stated, Fins help in better heat dissipation of motor by increasing its outer surfaces. [5]

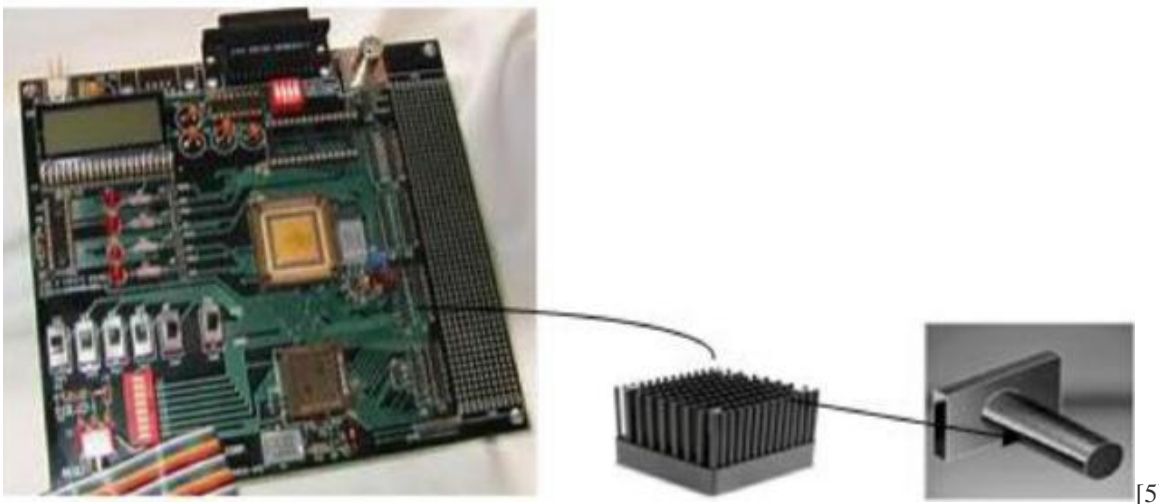

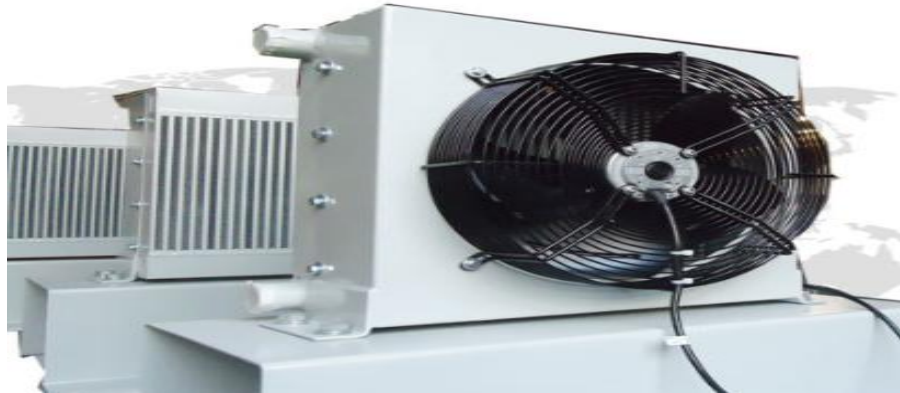

Figure: 17.

#### **Application of fin system to reduce pitch motion:**

The fixed bow fin system in waves serves as good controller for pitch motion and heave motion can also be controlled in certain cases.

The results show the fixed fin is very effective in a frequency range of 9 to 11 s wave period. In irregular seaway, an activated fin system may be more effective. By controlling the pitch motion the pitch motion characteristics of the ship is changed. It might be helpful in avoiding the parametric roll which is very much inherent with container ships with slender hull.

For a cruising speed of 25 knots, the rms value of the response for that particular sea state is achieved using the area under the pitch spectral curve.

The study can be taken as bench mark for application of fins and use of in a feedback control system of ship motion.<sup>[6]</sup>

#### **Dehumidification of surrounding air:**

There is a unique application of fins where cooling, as well as dehumidification of the surrounding air, can be achieved.

The dehumidification of air or the condensation of water vapor occurs only when the temperature of the fin is lower than the dew point temperature of the air passing across the fins.

In summer air conditioning, the surface temperature of the evaporator is maintained below the dew point temperature of the incoming air. As a result, combined heat and mass transfer occur between the cold surface (fin) and the air stream.

#### **Automobile vehicles:**

Finned surface are conventionally used in modern vehicle technology to enhance heat transfer is in the form of convection. Convection takes place between a solid surface and liquid medium. Due to the combustion process heat get produced inside the engine. During explosion the temperature of metal around the engine exceeds 1000°F. In order to prevent all this overheating of engine oil, piston, and cylinder walls, valves and other component, it is necessary to dispose the heat effectively then the Frontal area must be limited in order to gain the effective heat transfer rate.

Almost 30% of Combustion heat is used to run the vehicle then the next 60% released in to the atmosphere , the remaining heat is absorbed by the cooling system. Nowadays liquid cooling system is installed in all Car Engines. The coolant is circulated through radiator after absorbing the heat of combustion. Excessive cooling system is also a factor leads to affect engine working condition and performance.

#### **Hydrogen desorption by using honeycomb finned heat exchangers integrated in adsorbent storage systems**

Hydrogen fueled vehicles can readily compete with traditional liquid hydrocarbon fueled automobiles only if the energy density of the hydrogen stored on board can closely approach or achieve that of liquid fuels<sup>[8]</sup>.



Figure: 18.<sup>[8]</sup>

## X. CONCLUSION

As the fins are very important tool in engineering field hence its study is essential for better design and with minimum increment of weight and cost with optimum heat dissipation. The performance of the fin is dependent on fin geometry, fin materials and other parameters like fin height, fin spacing, weight of fin and cost for manufacturing it. We have discussed different types of fins with their classification and special modifications in fins. We have shown parameters which affect fins, efficiency and, effectiveness of fins with mathematical modeling in various conditions. We have presented a case study from previous researchers with thermal simulation of different geometry of fins with same base material in ANSYS15.0 and, we have also studied thermal simulation on different materials with same geometry (circular pin fin). We also mentioned various case studies of special applications of fins. This concept is followed by number of researches for their application. But still lot many work remains to be carried out in the future. This paper provides important basic information and the research trend in the field of heat dissipation for engineering applications which will be helpful for further research work in future.

## REFERENCES

1. K. Priyadharshini, "finite element analysis of radiator fins to increase the convection efficiency of radiator by using Al alloy, Cu and brass material.", *Journal of Advanced Engineering Research*, ISSN: 2393-8447, Volume 3, Issue 1, 2016, pp.78-82
2. Piyush Kumar Kashyap, priyanka jhavar, *Enhancement of Heat Exchanger Performance by the Extended Surfaces-Fins*, *International Journal of Engineering Trends and Technology (IJETT) – Volume 34 Number 6- April 2016*
3. Pardeep Singh, Harvinder lal, Baljit Singh Ubhi, *Design and Analysis for Heat Transfer through Fin with Extensions*, Vol. 3, Issue 5, May 2014, *IJIRSET*
4. L.Prabhu, M.Ganesh Kumar ,Prasanth M, Parthasarathy M, *DESIGN AND ANALYSIS OF DIFFERENT TYPES OF FIN CONFIGURATIONS USING ANSYS*, *International Journal of Pure and Applied Mathematics*, Volume 118 No. 5 2018, 1011-1017
5. George Oguntala a, Raed Abd-Alhameed a, Gbeminiyi Sobamowo b, Halimatu-Sadiyah Abdullahi a, *Improved thermal management of computer microprocessors using cylindrical-coordinate micro-fin heat sink with artificial surface roughness*, *Engineering Science and Technology, an International Journal* 21 (2018) 736–744
6. B. Rajesh Reguram , S. Surendran a, Seung Keon Lee , *Application of fin system to reduce pitch motion*, *International Journal of Naval Architecture and Ocean Engineering*
7. R. Sudheer kumar Reddy, Dr .k. Govinda Rajulu , Dr. S.M. Jameel Basha , E. Vijay Gowd , P. Veera Prathap, C.N. Vishnu Vandhan, *Thermal Analysis of Pin Fin with Different Shape Forms using ANSYS*, *International Journal of Engineering Science and Computing*, May 2017.
8. Claudio Corgnalea, Bruce Hardya, Richard Chahinec, Daniel Cossementc, *Hydrogen desorption using honeycomb finned heat exchangers integrated in adsorbent storage systems*, *journal homepage: [www.elsevier.com/locate/apenergy](http://www.elsevier.com/locate/apenergy)*.

9. *MODULE 3, Extended Surface Heat Transfer, NPTEL, Student\_Slides\_*